

proTAC™ 5020

promarine

Wideband VHF Communications Antenna (AIR VHF and Marine VHF)

proTAC 5020 compact and robust wideband VHF communications antenna for Search and Rescue and patrol boats is designed for demanding marine and military conditions.

proTAC 5020 wideband VHF communications antenna is a unique combination of aviation VHF and marine VHF frequencies. It covers the whole spectrum between 110-170MHz with good performance.

High performance and robust proTAC™ technology reduces design complexity of vessels' topside structures by radically minimizing the antenna count. It not only makes the design easier but it also reduces intermodulation interference and cross-talk that would otherwise occur in too densely located antenna environments.

Used together with Aviation VHF and Marine VHF Antenna Combiner -proFIL 4010 it is possible to use simultaneously up to two radios.

proTAC™ technology combines unique design and materials that minimize radar cross section, increases robustness and reduces interference while being compact in size.

Advanced features create advantage

- less interference
- requires ground plane
- compatible NATO-flange mount
- very compact and robust design
- aluminum and nylon body, replaceable carbon fibre whip
- designed to be used with proFIL 4010 and two radios
- can be used with proISO 1001 to prevent ground loops

Electromagnetic modelling services fine-tunes performance

Use our advanced proEMS™ electromagnetical simulation, modelling, analysis and measurement services to create a complete 3D-electromagnetic environment of the ships' external structures. This way the optimum location for each antenna with the least interference can be found and verified. The proEMS™ services are useful for any size of boat or ship and will be tailored for each customer separately.



Wideband VHF Communications Antenna (AIR VHF and Marine VHF)

Technical features

Antenna type:

Omnidirectional
Operational mode is monopole
Adequate ground plane and contact is required (>1 sqm)

Frequency range:

AIR: 118MHz - 137MHz
VHF: 150MHz - 170MHz
WIDE: 110MHz - 170 MHz

Antenna gain:

AIR: 1dBi
VHF: 1dBi

Return loss:

AIR: >10dB (max. 17dB)
VHF: >10dB (max. 15dB)
WIDE: >10dB

Powerhandling:

Continuous total 50W

Mounting:

NATO-flange mount with four bolts
O-ring supplied for sealing

Connector:

N-type female at bottom

Enviromental:

Case IP68 shock proof
Operating temp: -30° - +60°

Material:

Aluminium base
Carbon fibre radiator whip

Dimensions:

Height: 610 mm (without connector)
Width: 140 mm (base plate diameter)
Weight: 625 g

Order code:

ANT5020:
proTAC 5020 Wideband VHF Communications Antenna

Delivery time:

From stock (with reservations)

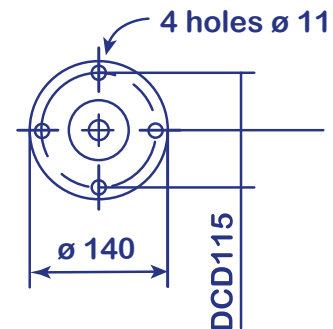

Dimensions:

Height: 610 mm

Width: 140 mm

Connection example

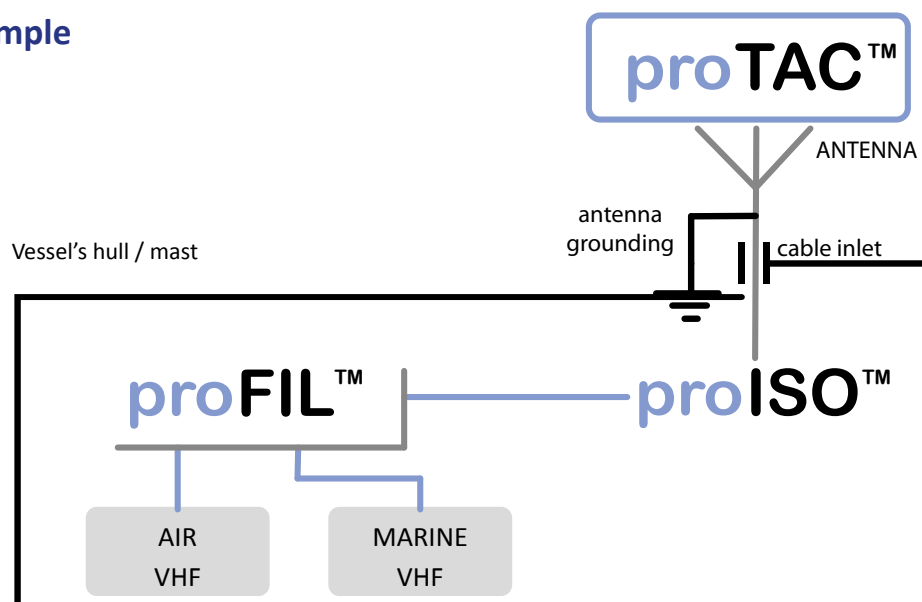

Cachet distributeur



Le spécialiste des équipements électroniques

Zac de la plaine - 1, rue Brindejone des Moulinais
31500 TOULOUSE
Tél : +33 (0)5 67 77 94 44 - Fax : +33 (0)5 67 77 94 49
info@pstfrance.com - www.pstfrance.com